

IGNITE

Department of Electrical and Electronics Engineering

Volume 11, Issue 1
2023-2024

TECHNICAL MAGAZINE

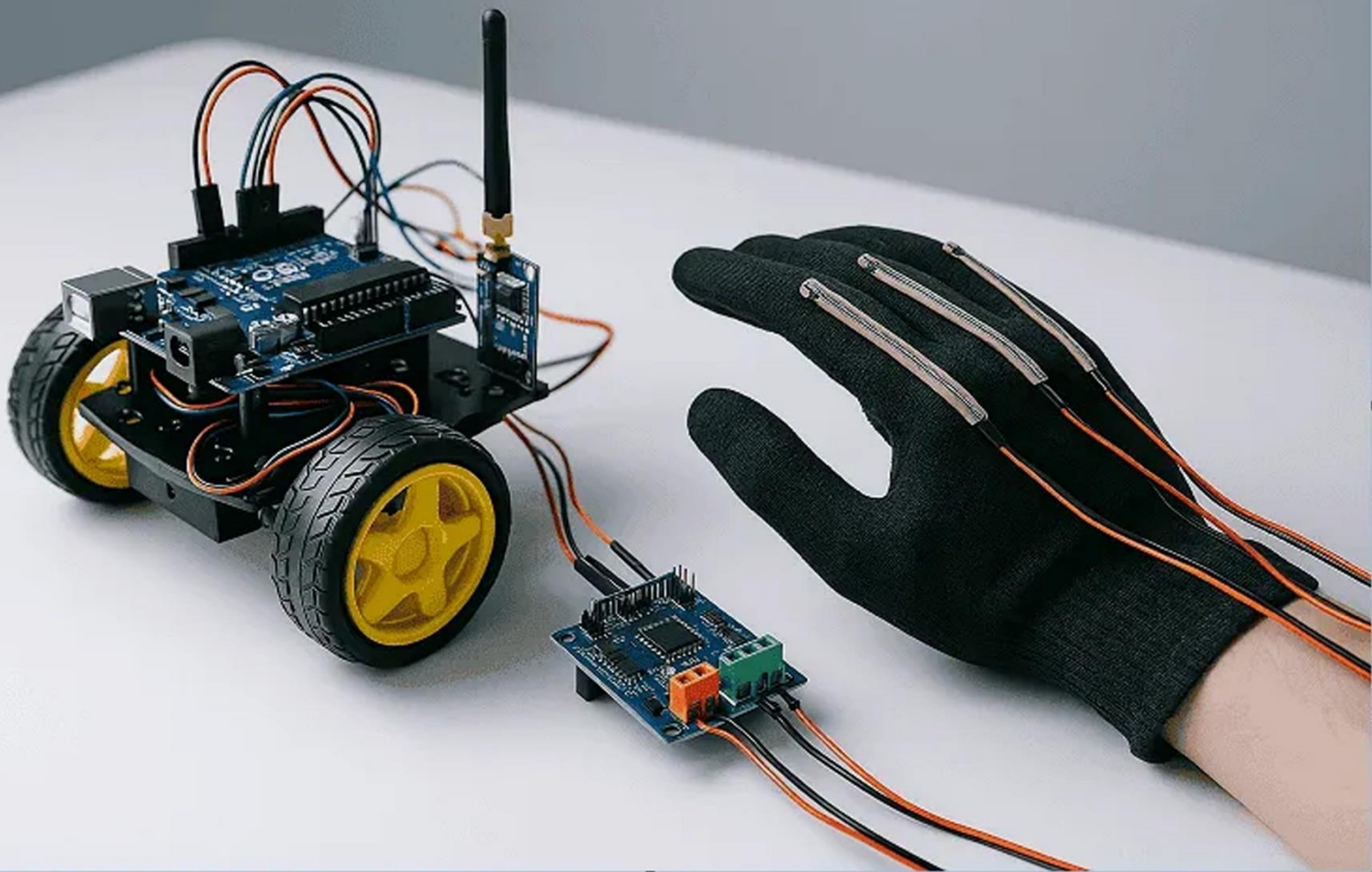

Gnanamani College of Technology

(An Autonomous Institution)

Accredited by NAAC 'A' Grade and NBA

NH-7, A.K.Samuthiram,

Pachal-PO, Namakkal-637 018, Tamil Nadu.

www.gct.org.in

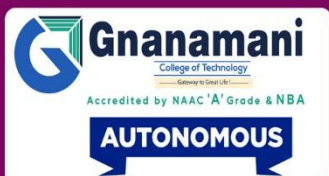

IGNITE

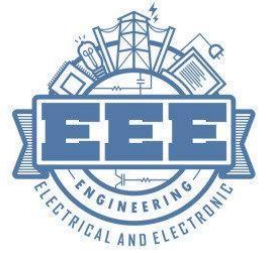

Technical magazine

It is to provide a platform for the students, teachers, technical as well as non-technical staff of the college to express their work, ideas, views, opinions, etc. related to science and technology. They provide a platform for faculty and students to publish articles, share technical expertise, and highlight achievements, ultimately driving awareness of recent trends and enhancing technical skills.

Editorial Board

Faculty Coordinator:

- Dr.J.Chandramohan HOD/EEE
- Mr.K.Satheeshkumar AP/EEE

Student Coordinator:

- MADHUNISHA M
- VIJAY P
- LAKSHMIPATHI P
- CHANDRU D
- KIRUTHIKA T



Gnanamani College of Technology
(Approved By AICTE & Affiliated to Anna University, Chennai)
Accredited By NAAC "A" Grade & NBA
NH-7, A Samuthiram, Pachal (P.O.), Namakkal - 637018
Department of Mechanical Engineering

GNANAMANI EDUCATIONAL INSTITUTIONS

Gnyanamani Educational Institutions that have carved a niche for itself in the field of engineering education within a very short span of time. Gnanamani College of Technology which was established in the year 2006, the group comprises of Gnanamani College of Education, established in the year 2005.

Gnanodaya CBSE International School was established in the year 2015. These Institutions serve under the aegis of The Christian Educational Development Trust.

Gnyanamani Educational Institutions were established in a well-planned campus with a green environment. The Colleges are spread on a sprawling 60 acres of serene land. The Colleges are easily accessible from all major cities by road and railway networks.

These Institutions have emerged as a pioneer venture in the field of Technical Education. Dr.T.Arangannal – a Rashtria Vidhya Saraswathi Puraskar Awardee is the Chairman and Mrs.P.Malaleena is the Chairperson of the Educational Institutions.

GNANAMANI COLLEGE OF TECHNOLOGY

Gnanamani College of Technology is a leading Institution with state-of-the-art facility.

The institution is rendering noble service to the youths in rural and urban areas.

The college is accredited by the NAAC and NBA (CSE, ECE, EEE, and Mechanical). The college has grown in a short span of 17 years with 12 UG Courses namely Agricultural, Artificial Intelligence and Data Science, Bio-Medical, Biotechnology, Chemical, Computer Science, Electrical and Electronics, Electronics and Communication, Food Technology, Mechanical, Information Technology and Pharmaceutical Technology.

The Institute also offers 9 PG courses in Computer Science, Construction Engineering and Management, Environmental Engineering, Embedded System Technology, Power Electronics and Drives, Industrial Engineering, VLSI Design, BME, MBA and MCA.

INSTITUTE VISION

Emerging as a technical institution of high standard and excellence to produce quality Engineers, Researchers, Administrators and Entrepreneurs with ethical and moral values to contribute the sustainable development of the society.

INSTITUTE MISSION

We facilitate our students

- To have in-depth domain knowledge with analytical and practical skills in cutting edge technologies by imparting quality technical education.
- To be industry ready and multi-skilled personalities to transfer technology to industries and rural areas by creating interests among students in Research and Development and Entrepreneurship.

DEPARTMENT OF ELECTRICAL AND ELECTRONICS ENGINEERING

The Electrical and Electronics Engineering Department was started in the year 2006 and accredited by NBA in 2019. It offers B.E. with 60 student intake, M.E. – PED, M.E.—EST and Ph.D.in Full time and Part time modes. The department has 12 Curriculum Laboratories and 2 Industry supported labs providing 8 Value added courses and a Centre of Excellence – IOT Laboratory. Anna University recognized Research & Development Centre with 2 Ph.D., Supervisors and 4 Doctorates is fully functioning in the department since 2015. The faculty of the department have published more than 190+ reputed journal publications, 4 Patents and have received a project grant of 15 Lakh. The Department has 2 Professional Societies namely ISTE and IEI.

The Department of Electrical and Electronics Engineering (EEE) is committed to excellence in teaching, learning, research, and innovation. The department offers a strong academic foundation combined with practical exposure in emerging areas such as power systems, power electronics, electric vehicles, renewable energy, control systems, embedded systems, IoT, and VLSI. With well-qualified faculty, modern laboratories, and industry interaction, the department strives to produce competent engineers with professional ethics and social responsibility.

VISION

- Providing quality education for the sustainable development in the field of Electrical and Electronics Engineering to meet the global standards and to produce socially responsible engineers with ethical and moral values.

MISSION

- Imparting the quality technical education through state of the art infrastructure and modern tools.
- Making the students as professionals with ethical values, economical, ecological and social upliftment.
- Extending the sustainable knowledge through research and entrepreneurship for the benefits of humanities.

PROGRAM EDUCATIONAL OBJECTIVES

Graduates of Electrical and Electronics Engineering will

PEO-1: Have strong foundation in mathematics, science, and engineering fundamentals and advanced concepts towards their successful career in industries, research and entrepreneur.

PEO-2: Analyze, design and implement various electrical, electronics and interdisciplinary projects, addressing the industrial and social needs.

PEO-3: Have effective communication and leadership skills with ethical values.

PROGRAM SPECIFIC OUTCOMES

Graduates of the program will be able to

PSO-1: Attain in-depth knowledge and design skills in Electrical Power Systems, Electrical Drives, Power Electronics and Control, Electronics and Digital Electronics.

PSO-2: Acquire specialized skills in Solar Power Applications, High Voltage Engineering and competency for competitive examinations.

PROGRAM OUTCOMES

Engineering knowledge:

Apply the knowledge of mathematics, science, engineering fundamentals and an engineering specialization to the solution of complex engineering problems

Problem analysis:

Identify, formulate, review research literature, and analyze complex engineering problems reaching substantiated conclusions using first principles of mathematics, natural sciences and engineering sciences.

Design/development of solutions:

Design solutions for complex engineering problems and design system components or processes that meet the specified needs with appropriate consideration for the public health and safety, and the cultural, societal and environmental considerations.

Conduct investigations of complex problems:

Use research-based knowledge and research methods including design of experiments, analysis and interpretation of data and synthesis of the information to provide valid conclusions.

Modern tool usage:

Create, select, and apply appropriate techniques, resources, and modern engineering and IT tools including prediction and modeling to complex engineering activities with an understanding of the limitations.

The engineer and society:

Apply reasoning informed by the contextual knowledge to assess societal, health, safety, legal and cultural issues and the consequent responsibilities relevant to the professional engineering practice.

Environment and sustainability:

Understand the impact of the professional engineering solutions in societal and environmental contexts, and demonstrate the knowledge of, and need for sustainable development.

Ethics:

Apply ethical principles and commit to professional ethics and responsibilities and norms of the engineering practice.

A Individual and team work:

Function effectively as an individual and as a member or leader in diverse teams, and in multidisciplinary settings.

Communication:

Communicate effectively on complex engineering activities with the engineering community and with society at large, such as, being able to comprehend and write effective reports and design documentation, make effective presentations, and give and receive clear instructions.

Project management and finance:

Demonstrate knowledge and understanding of the engineering and management principles and apply these to one's own work, as a member and leader in a team, to manage projects and in multidisciplinary environments.

Life-long learning:

Recognize the need for, and have the preparation and ability to engage in independent and life-long learning in the broadest context of technological change.



MANAGEMENT PROFILE



Gnyanamani Educational Institutions are run by two legendary visionaries, Dr. T. Arangannal and Mrs. P. Malaleena, whose dedication to education has shaped the institution's identity and direction.

At the forefront is Dr. T. Arangannal, Chairman, a distinguished leader, who has been a driving force behind the institution's evolution. A recipient of the Rashtriya Vidya Saraswati Puraskar and an honorary Doctorate from the University of Sri Lanka, Dr. Arangannal is widely revered for his lifelong contributions to the field of education. His visionary leadership has cultivated a culture of excellence, discipline, and innovation across all levels of the institution.

Mrs. P. Malaleena, Chairperson, whose unwavering commitment and strategic foresight have been instrumental in establishing the institution's strong ethical and academic foundations. Her focus on student-centered learning and inclusive growth continues to define its mission, vision, and core values.

The leadership team also includes Ms. Madhuvanthinie Arangannal, Vice-Chairperson, who brings a contemporary vision and strategic insight to the institution's development. Her dynamic leadership focuses on aligning the institution with global academic standards and fostering innovation in education.

Operational administration is efficiently managed by Dr. P. Premkumar, Chief Administrative Officer, whose expertise in institutional management and policy implementation ensures the smooth functioning of all academic and support services. His strategic leadership plays a vital role in sustaining and enhancing the institution's quality standards.

Academic affairs are led by Dr. T.K. Kannan, Principal, who is committed to providing a rigorous and engaging academic environment. His leadership promotes research-driven teaching, skills development, and student empowerment, ensuring that learners are prepared to meet the demands of a rapidly changing global landscape.



CHAIRMAN'S MESSAGE



It gives me immense pleasure to express that our Electrical and Electronics Engineering release the department magazine for the academic year 2023-24 highlighting the various activities and budding talents of the students on this special occasion. I value the emerging ability and the endowment of the students in their articles, poems, drawing etc., which bloom out their young talents and skills. I appreciate our magazine committee for their venture in bring out this memorable edition.

I wish the Principal, Magazine Committee and the Editorial team, Staff and Students and all the hands that rendered service to bring out a fabulous magazine for this year, I am passionately waiting for the editorial team to reach another mile stone of perfection in the next magazine. I wish them all success.

Dr. T. Arangannal



CHAIRPERSON'S MESSAGE



I am glad to know that our Gnanamani College of Technology is leading a step forward by releasing the magazine 2023-2024. This magazine would be a common platform for the students to express their hidden talents and creativity. My hearty wishes to the Principal, staff members and students for the completion of this IGNITE.

Wishing you all success in their Academic Endeavours.

Tmt.P.Malaleena



VICE CHAIRPERSON'S MESSAGE



IGNITE is particularly important as it encourages the students to share the knowledge they have acquired. Writing articles for the magazine also improves the communication skills of the budding engineers of the EEE department. It is common knowledge that representation of an idea is as important as, if not more important, than the idea itself.

I would like to congratulate the faculty and the students of the editorial team on bringing out the issue of IGNITE and my best wishes to the students for a bright future.

Ms. Madhuvanthinie Arangannal



CAO'S MESSAGE



It is my privilege to know that Department of Electrical and Electronics Engineering releasing its achievements in a nutshell in the form of a magazine. This magazine is a skylight which always exhibit innovative and the creative thoughts of the blooming engineers. I take this opportunity to congratulate and wish all faculty members and students success.

Dr.P.Premkumar



PRINCIPAL'S MESSAGE



IGNITE represents a cloud with a silver lining for the world of technology. It aims to inspire and nurture upcome-world of technology. The magazine captures the current engineers to bring a revolution in this ever evolving technological advancements.

I would like to congratulate the vice principal, HoD, Staff members and students for bringing out the issue of IGNITE.

Dr. T.K. Kannan



HOD'S MESSAGE



Congratulations to the students and faculty associated to magazine committee for successfully publishing the issue of departmental technical magazine IGNITE. IGNITE is creating platform which provides an opportunity to the students and staff to express their original thoughts on technical topics.

The magazine plays an instrumental role in providing exposure to the students to develop written communication skills and command over the language. It is a step towards building professional and ethical attitude in them. The entire journey of creating IGNITE is an outcome of rigorous effort made by students and faculty.

On concluding note, I would like to thank all the stakeholders for their involvement and encouragement and wish all the best for their bright future.

Dr. J.Chandramohan

TABLE OF CONTENTS

Sl. No.	Topic	Activity Type	Presented by
1.	PLC in Industrial Automation	Tech Knowledge	Dr.R.Nagarajan Prof/EEE
2.	Internet Of Things-Aided Smart Grid	Tech Knowledge	Dr.M.Malarvizhi Prof/EEE
3.	Medical Robots	Tech Knowledge	M.Madhunisha IV/EEE
4.	Modern Electric Drives	Tech Knowledge	M D Arbaj III/EEE
5.	Space Sensors	Tech Knowledge	M.Abinaya III/EEE
6.	Village Life	Pencil Art	D.Chandru IV/EEE
7.	National Leaders	Pencil Art	G.Harish II/EEE
8.	Swami Ayyappa	Pencil Art	M. Dhinesh Kumar II/EEE
9.	நான் வீழ்வேனென்று நினைத் தாயோ?	கவிதை	R.Mahalakshmi II/EEE
10.	உழைப்பின் உயர்வு	கவிதை	S.Deepadharshini III/EEE
11.	பசுமையின் அழகு	கவிதை	S.Monasri II/EEE
12.	கடலின் கவிதை	கவிதை	M.Ramkumar II/EEE
13.	Ratan Tata	Biography	Lakshmipathi.P III/EEE

Tech Knowledge

PLC in Industrial Automation

Nowadays, time is very important to the industry and people. For example, we all need the quality of products used in daily life. Automobile manufacturing, solar tracking, wind energy, HVAC control, all these processes require automation and control systems. The control system automatically controls all processes that we don't have to manage manually. After globalization, the industry has undergone tremendous changes, and various devices are used to control the process, for example Industry 4.0 issued by the German government. In India, all operations are controlled by a programmable logic controller (PLC). In 1969, the first PLC was used in the automotive industry. At present, industrial control, especially PLC is an important technical basis for industrial process automation. Yet in the era of industry 4.0 and the Industrial Internet, it can be supposed that these controllers will still be in great demand in future production.

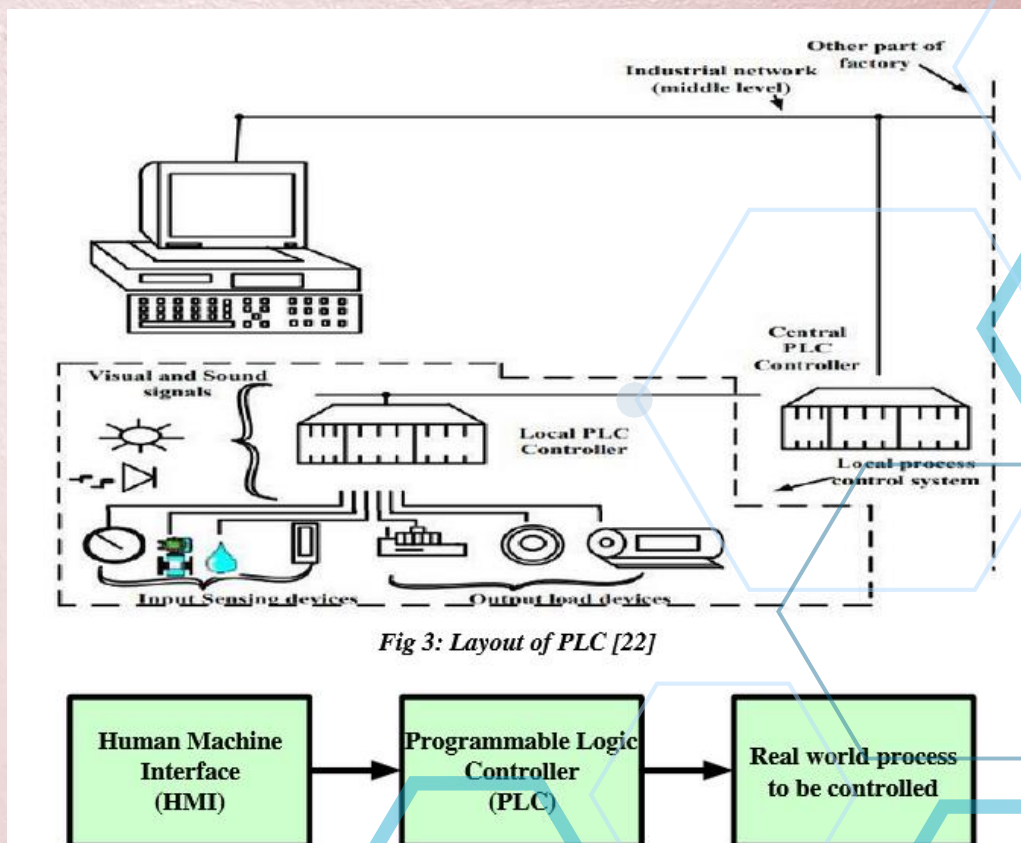

However, the controller necessity meets a series of further needs brought about by the new manufacturing circumstances. While, applying the principles of Industry, a high standard manufacturing system is based on a cyber-physical production system (CPPS). Therefore, the ability of programming based manufacturing system will play a significant task.



In the circumstance of Industry, rapid constructive validation and changes in the technological process of industrialized exact goods will occur frequently and have turned into routine tasks. As a result, the rapid and simple change of factory design, and apparatus and the reshaping of its performance are the fundamentals for automated industrialized systems in Industry 4.0.

Dr.R.NAGARAJAN Prof/EEE

Internet of Things-Aided Smart Grid

The “grid” is the electrical network serving every resident, business and infrastructure service in a city. The “smart grid” is the next generation of those energy systems, which have been updated with communications technology and connectivity to drive smarter resource use, energy efficiency, and reduced carbon footprint. The technologies that make today’s IoT-enabled energy grid “smart” include wireless devices such as sensors, radio modules, gateways and routers. These devices provide the sophisticated connectivity and communications that empower consumers to make better energy usage decisions, allow cities to save electricity and expense, and enables power authorities to more quickly restore power after a blackout.

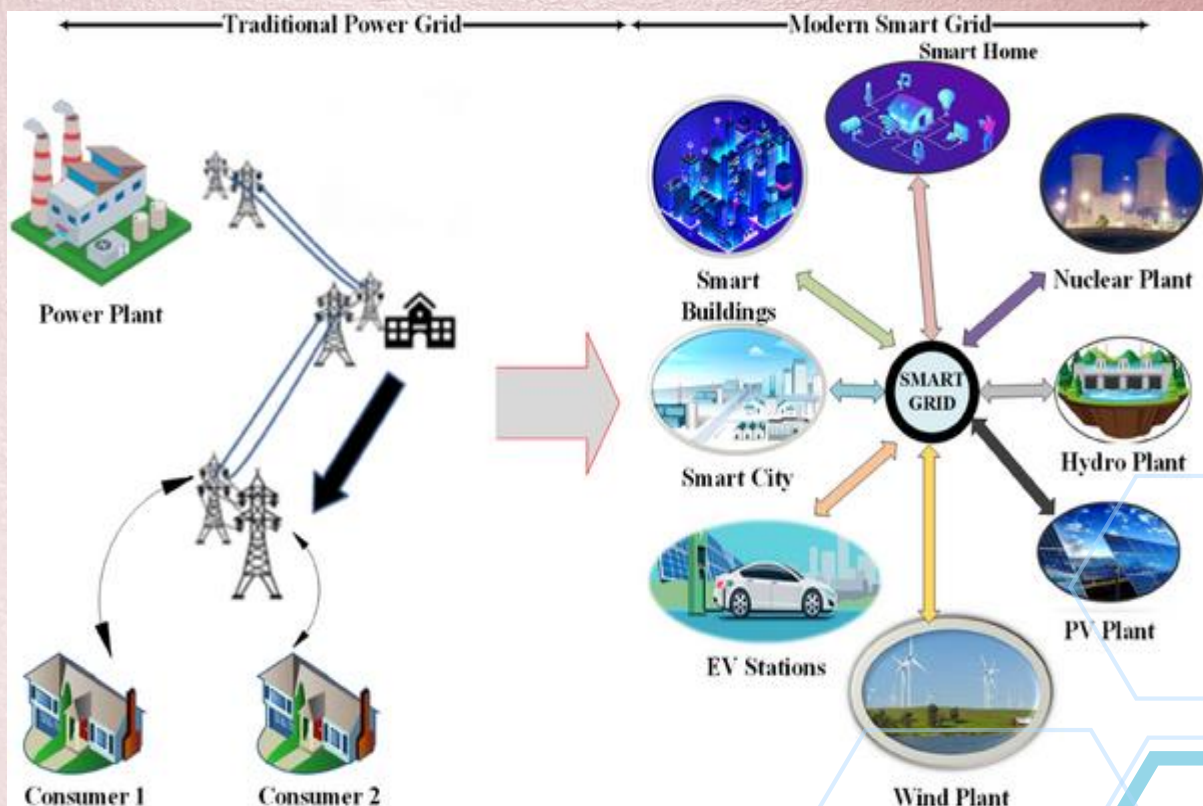

IOT Smart Energy Grid is based on ATmega family controller which controls the various activities of the system. The system communicates over internet by using Wi-Fi technology. A bulb is used in this project to demonstrate as a valid consumer and a bulb to demonstrate an invalid consumer. The foremost thing that this project facilitates is re-connection of transmission line to active grid. If an Energy Grid becomes faulty and there is an another Energy Grid, the system switches the Transmission Lines towards this Grid thus facilitating

uninterrupted electricity supply to that particular region whose Energy Grid went OFF. And this information of which Grid is active is updated over IOTGecko webpage where the authorities can login and can view the updates. Apart from monitoring the Grid this project has advanced capabilities of monitoring energy consumption and even detect theft of electricity.

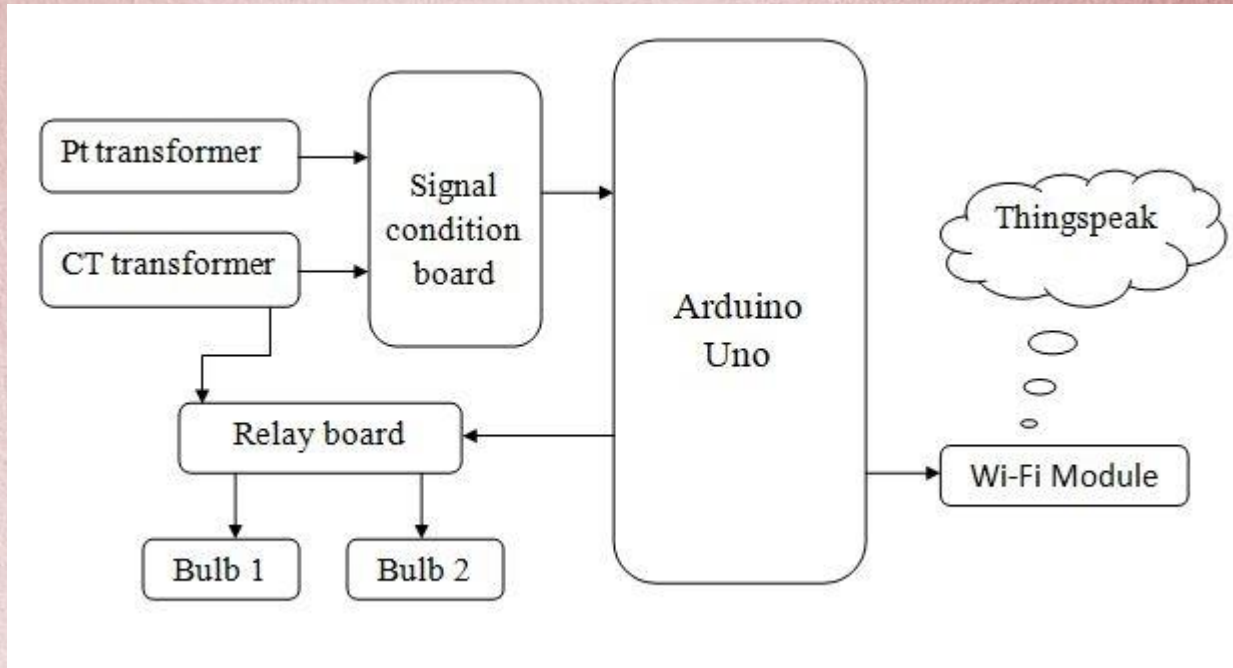

The amount of electricity consumed and the estimated cost of the usage gets updated on the IOTGecko webpage along with the Energy Grid information. Theft conditions are simulated in the system using two switches. Switching one each time will simulate a theft condition and also will notify the authorities over the IOT interface. In this way the Smart Energy Grid project makes sure that the electricity supply is continuous and helps in maintaining a updated record of consumption and theft information which is quite a valuable information for the energy producing companies.

Mrs.P.PUSHPARANI AP/EEE

Medical Robots

Artificial intelligence and robotics are two technologies that have demonstrated the potential to address and provide solutions to numerous contemporary issues. The manufacturing sector has been using robotics for quite a long time. However, over the past three to four decades, robots have been in use in other sectors as well, such as laboratory research, earth and space exploration, transport, and many more. The use of robots has lowered production costs and increased productivity, while simultaneously leading to the creation of many new jobs in the tech sector, contributing to economic growth. Robots are mainly employed where the tasks require repetitive and monotonous work; however, with Artificial Intelligence (AI), the scope is widening.

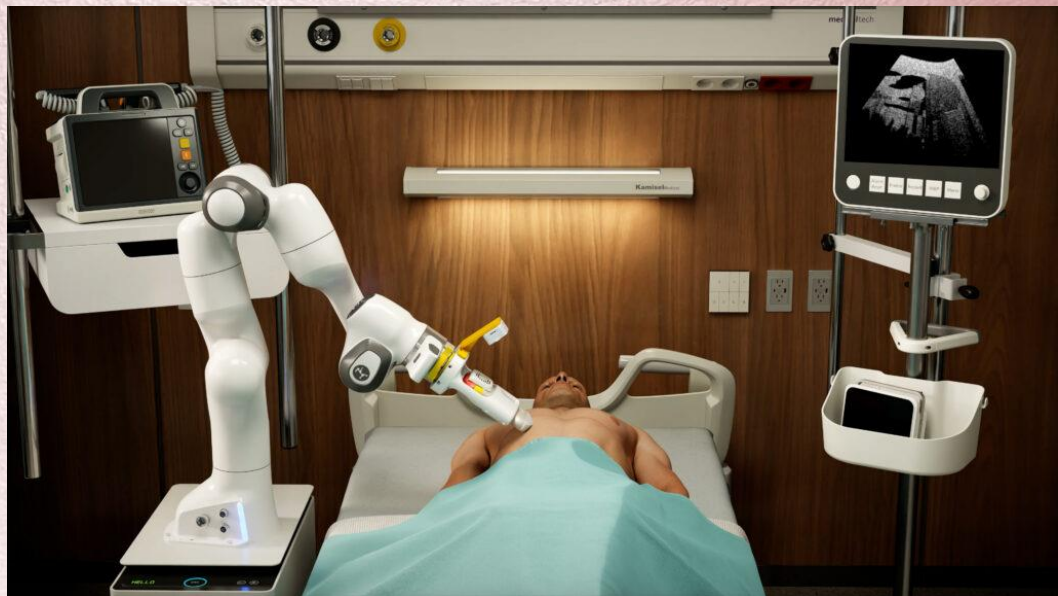

In surgery, medical roboticists work to create surgical assistants that collaborate in the operating room to improve precision and efficiency. In diagnostics, medical robots seek to improve the detection of disease and make tests more comfortable for patients. They then create prototypes and perform proof of concept studies in simulation, rapidly iterating on designs to improve performance, efficacy, and safety. Next, for appropriate projects, they conduct human studies with volunteers and Michigan Medicine patients to understand how well their robots function in their target clinical area. Finally, when devices demonstrate a significant positive impact, they form startups or coordinate with medical robotics companies to scale up the technology for broader patient use.

M.MADHUNISHA
IV YEAR

Modern Electric Drives

Modern electric drives play a vital role in today's electrical and industrial systems by enabling efficient and precise control of electric motors. A typical electric drive system consists of a power source, power modulator, motor, control unit, sensing elements, and the mechanical load. The power source may be an AC supply, DC supply, or battery system, especially in electric vehicles. The power modulator, which includes devices such as rectifiers, inverters, and choppers, controls the flow of electrical energy to the motor by converting it into a suitable form. The control unit, usually implemented using microprocessors, digital signal processors (DSP), or programmable logic controllers (PLC), generates appropriate control signals, while sensors provide feedback regarding speed, current, or position for accurate operation.

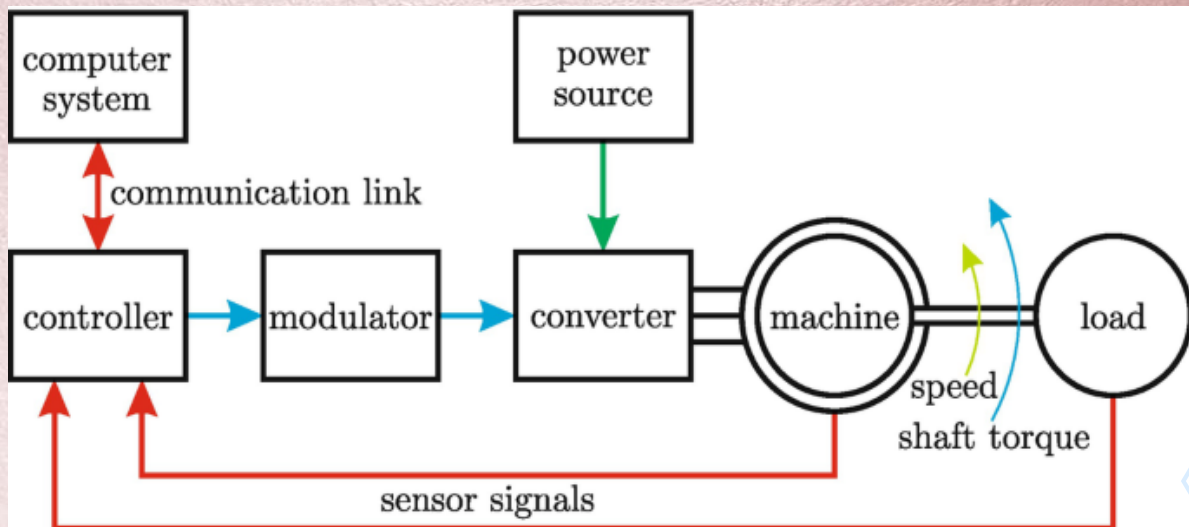

Electric drives can be broadly classified based on power supply into AC drives and DC drives. AC drives, especially Variable Frequency Drives (VFDs), are widely used in modern applications due to their efficiency and ability to control motor speed by varying the supply frequency and voltage. DC drives, although less common today, are still used in applications requiring precise speed control such as cranes and rolling mills. Based on control strategy, drives may be open-loop or closed-loop systems, where closed-loop drives use feedback to improve accuracy and stability. Additionally, based on application, electric drives can be categorized as constant speed drives, variable speed drives, and servo drives, with servo drives offering high precision control in robotics and CNC machines.

Space Sensors

Sensors play a crucial role in space systems by enabling spacecraft and satellites to monitor their environment, maintain proper functioning, and ensure accurate navigation. In space applications, sensors are used to measure physical parameters such as temperature, pressure, radiation levels, position, velocity, and orientation. Since space is a harsh environment with extreme temperatures, vacuum conditions, and high radiation, sensors must be highly reliable, precise, and capable of operating without maintenance.

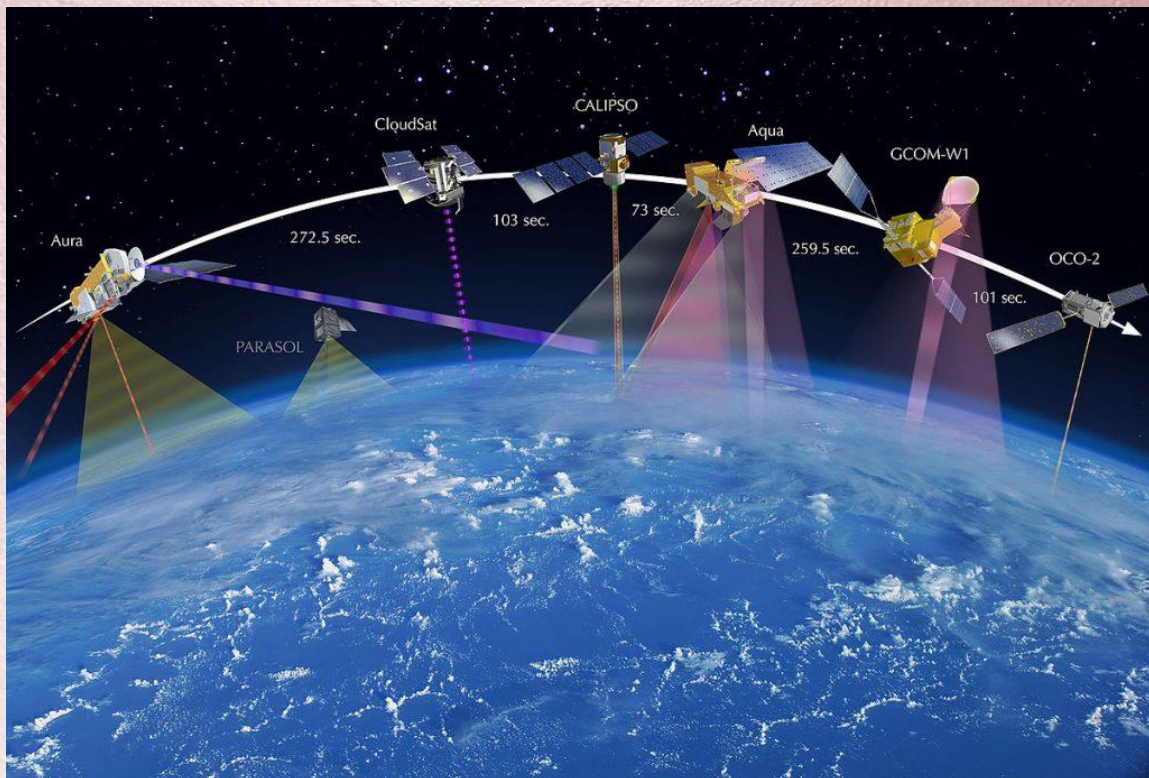

Common sensors used in space include temperature sensors to monitor thermal conditions, gyroscopes and accelerometers for motion and orientation detection, star trackers for precise attitude determination, and radiation sensors to detect harmful cosmic rays. These sensors provide essential data to onboard control systems, which use the information to adjust spacecraft operations, stabilize orientation, and ensure mission success. Advanced space missions also use imaging sensors and remote sensing devices to collect scientific data about planets, stars, and Earth. Overall, sensors act as the “eyes and ears” of spacecraft, playing a vital role in navigation, control, safety, and scientific exploration in space.

PENCIL ART

VILLAGE LIFE



CHANDRU D
IV YEAR

National Leaders



HARISH.G

II YEAR

SWAMI AYYAPPA

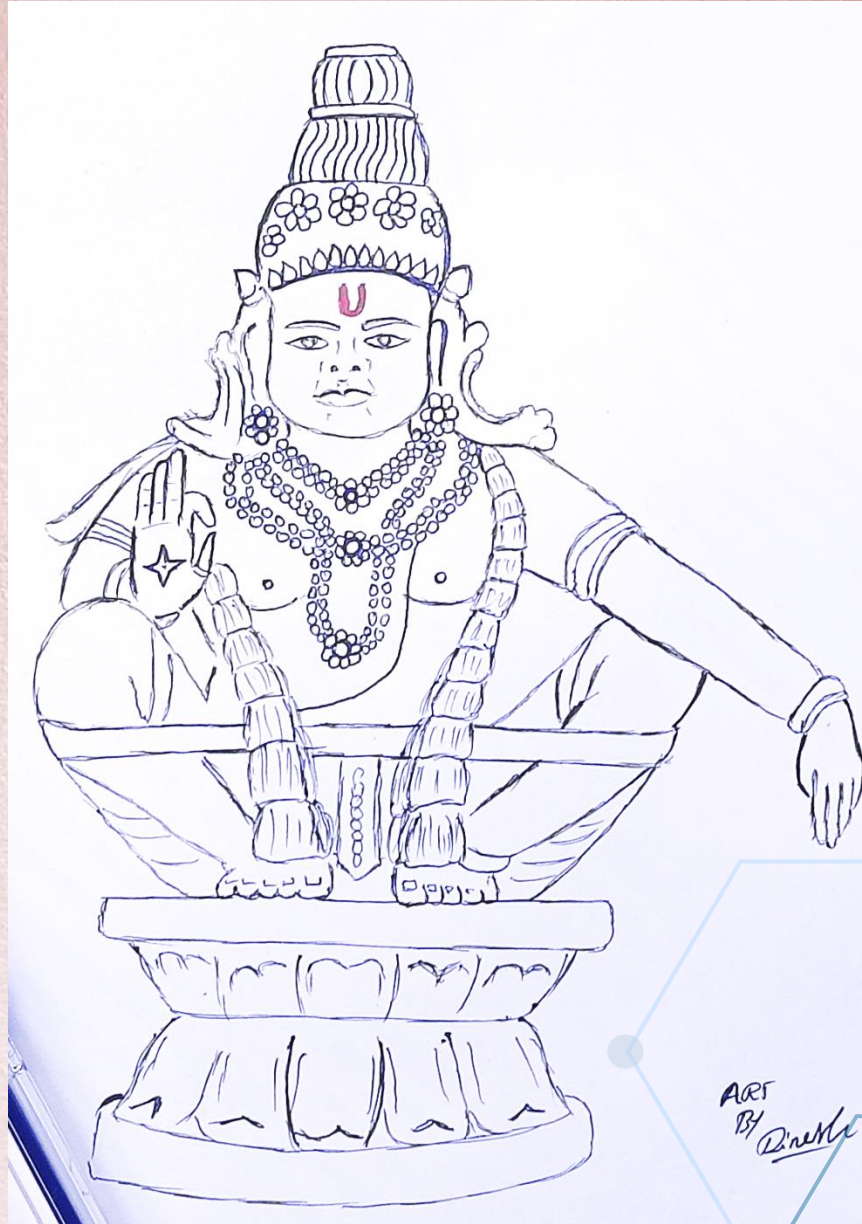

DHINESH KUMAR M
II YEAR

POEMS

நான் வீழ்வேனென்று நினைத் தாயோ?

தேடிச் சோறுநிதந் தின்று - பல
சின்னஞ் சிறுகதைகள் பேசி - மனம்
வாடித் துன்பமிக உழன்று - பிறர்
வாடப் பலசெயல்கள் செய்து - நரை
கூடிக் கிழப்பருவ மெய்தி - கொடுங்
கூற்றுக் கிரையெனப்பின் மாயும் - பல
வேடிக்கை மனிதரைப் போலே - நான்
வீழ்வே எனென்றுநினைத் தாயோ?

நின்னைச் சிலவரங்கள் கேட்பேன் அவை
நேரே இன்றெனக்குத் தருவாய் - என்றன்
முன்னைத் தீயவினைப் பயன்கள் - இன்னும்
மூளா தழிந்திடுதல் வேண்டும்-இனி
என்னைப் புதிய வுயிராக்கி-எனக்
கேதுங் கவலையறச் செய்து - மதி
தன்னை மிகத்தெளிவு செய்து - என்றும்
சந்தோஷங் கொண்டிருக்கச் செய்வாய்...

MAHALAKSHMI R
II YEAR

உழைப்பின் உயர்வு

காலை சூரியன் போல எழுந்து நீ பிரகாசி
கனவுகள் உன்னுள் இருக்கும் வரை நீ வெற்றி வாசி
அடிக்கடி வரும் தடைகள் உன்னை சோதிக்குமே
அதை தாண்டி செல்லும் மனம் உன்னை உயர்த்துமே
பயம் என்ற சங்கிலியை உடைத்து நீ பறந்து விடு
உன் திறமை மீது நம்பிக்கை வைத்து முன்னேறு
உழைப்பே உன் வெற்றியின் முதல் அடிக்கல்

S.DEEPADHARSHINI

III YEAR

பசுமையின் அழகு

பசுமை நிறைந்த புல்வெளி கண்களை கவரும்
பனித்துளி முத்துக்கள் இலைகளில் ஜொலிக்கும்
சூரியன் ஒளியில் பூமி புதுமை பெறும்
சின்ன சின்ன காற்று மனதை வருடும்
குயிலின் குரல் காலை நேரம் எழுப்பும்
நதிகள் ஓடி வாழ்க்கையை வளர்க்கும்
இயற்கை நம்மை நேசிக்கும் தாய் போன்றது
அதை பாதுகாப்பது நம் பொறுப்பு தான்

S.MONASRI

II YEAR

கடலின் கவிதை

கடல் அலைகள் கரையை தழுவும் இசை
ஆழம் கொண்ட ரகசியம் நிறைந்த உலகம்
நீல வானம் அதனுடன் இணைந்து காணும்
அலை வரும் போதும் உயிர் ஊற்றாகும்
மீன்களின் உலகம் அதில் வாழ்கிறது
மணல் கரைகள் அதன் அழகை காட்டும்
கடல் நமக்கு அமைதியை கற்றுத் தரும்
அதை காப்பது நம் கடமை ஆகும்

RAMKUMAR M
II YEAR

BIOGRAPHY

Ratan Tata

Introduction

Ratan Naval Tata is one of India's most respected industrialists and philanthropists, widely known for his visionary leadership and ethical values. Born on December 28, 1937, in Mumbai, he belongs to the prestigious Tata family, which has played a significant role in shaping India's industrial growth. He served as the chairman of the Tata Group from 1991 to 2012 and later as its interim chairman from 2016 to 2017. Under his leadership, the Tata Group expanded globally and became one of the most reputed business conglomerates in the world.

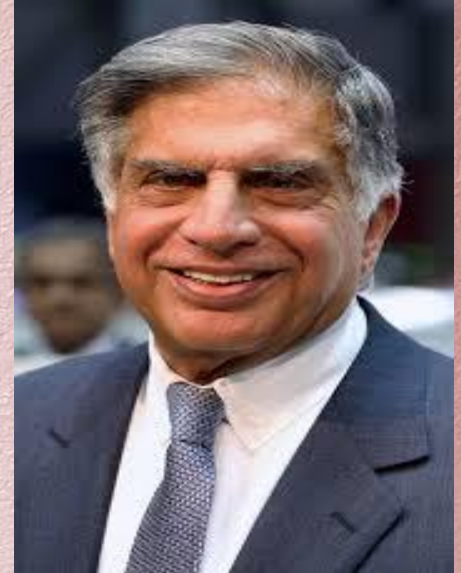

Early Life and Education

Ratan Tata was born to Naval Tata and Soonoo Tata. After his parents separated when he was young, he was raised by his grandmother, Lady Navajbai Tata, who had a strong influence on his values and character. He completed his schooling in Mumbai and later moved to the United States for higher education. He earned a degree in architecture and structural engineering from Cornell University in 1962. He also attended the Advanced Management Program at Harvard Business School in 1975, which enhanced his leadership and managerial skills.

Career and Rise in Tata Group

Ratan Tata began his career in 1962 by joining the Tata Group and working on the shop floor of Tata Steel, where he handled basic tasks alongside workers. This experience helped him understand the practical aspects of business operations. Over the years, he held various positions within the group and gradually rose through the ranks. In 1991, he succeeded J.R.D. Tata as the chairman of the Tata Group. At that time, the group consisted of many

independent companies operating separately. Ratan Tata brought a unified vision and restructured the organization, emphasizing innovation, global expansion, and brand identity. He encouraged younger leadership and modern management practices, transforming the Tata Group into a globally competitive entity.

Major Achievements and Contributions

One of Ratan Tata's significant contributions was expanding the Tata Group's presence internationally. Under his leadership, Tata acquired several global companies, including Jaguar Land Rover in 2008, which became a highly successful venture. Other notable acquisitions include Tetley Tea and Corus Steel, which strengthened Tata's global footprint. Ratan Tata is also known for launching the Tata Nano in 2008, which was introduced as the world's most affordable car, aimed at making car ownership accessible to middle-class families in India. Though it faced challenges in the market, the Nano remains a symbol of innovative thinking and social intent.

He played a crucial role in strengthening Tata Consultancy Services (TCS), which became one of the world's leading IT service providers. His focus on technology, quality, and customer satisfaction helped the group achieve global recognition.

Awards and Recognition

Ratan Tata has received numerous national and international awards for his contributions to industry and society. The Government of India honored him with the Padma Bhushan in 2000 and the Padma Vibhushan in 2008, which are among the country's highest civilian honors.

LAKSHMIPATHI.P

III YEAR



“ I admire people who are very successful. But if that success has been achieved through too much ruthlessness, then I may admire that person less. ”

— Ratan Tata —